

The Ricardo diesel engines was designed in advance of today's uncompromising demands within the power generation industry and includes superior performance and reliability. R series diesel engine is a four-stroke, vertical water-cooled, inline and direct injecting combustion chamber type, high-speed diesel engine.

Their premium design and specification features provide economic and durable operation as well as exceptional power to weight ratio, improved serviceability, low gaseous emissions, overall performance and reliability essential to the power generation market.

Introduction to Model Naming

R 6 100 Z D 1-2

⑦ ⑥ ⑤ ④ ③ ② ①

①: distinguish symbol, expressed with number sequence

②: version symbol, expressed with number sequence

③: uygulama özellik sembolü, alfabeyle ifade edilir
no alphabet: for common usage; T: for tractor; G: for engineering machinery; Q: for

vehicle; D: for generating set; C: for marine usage; P: for power take-off unit

④: construction feature symbol, expressed with alphabet; no alphabet: for natural aspirated model; Z: for turbocharged model.

⑤: cylinder bore (mm)

⑥: cylinder number

⑦: series symbol; stand for imported from RICARDO

General Data

1. Intake and Exhaust System

- Intake pipe - Aluminum single block type
- Exhaust pipe - A single block cast one
- Air filter - Single stage paper filter element style
- Double stages paper filter element style
- Silencer
- Turbocharger

2. Fuel System

- Fuel delivery pump
- Fuel filter - Brand: BALDWIN
- Model: Filter1-BF9853
Filter2-BF9821
- High pressure pump – type A
- Governor - Mechanics/Electronics
- Injector - Spring low installed and low inertia types
- J series and S series injector

3. Lubrication System

The engine is lubricated by pressure oil combined with splash oil.

- Oil pump - gear type oil pump
- Overload overflow valve
- Oil filter - JX0811A, J1012B type for engine lubricating oil
- JO506 type for turbocharger lubricating oil
- Oil cooler - pipe & shell type oil cooler

4. Cooling System

- Forced water cooling
- Radiator
- Water pump fan
- Thermostat
- Oil cooler

Technical Data

General		
Power, Standby 1500 rpm	121 kWm	
Power, Prime 1500 rpm	110 kWm	
Cylinder Volume	6,75 liter	
Number of Cylinders and Type	6 line	
Cylinder Sequence	1-5-3-6-2-4	
Aspiration and Cooling	Turbocharged / Aftercooler	
Engine RPM	1500 rpm	
Bore and Stroke	105x130 mmxmm	
Intake and exhaust system		
Intake Air Capacity	10,5 m ² /min	
Exhausted Gas Capacity	27 m ² /min	
Fuel system		
Fuel Tank Capacity	250 liter	
Governor Type	Mechanics/Electronics	
Lubrication System		
Oil Capacity	18 liter	
Cooling System		
Water Capacity(Radiator and Engine)	25 liter	
Weight		
Weight	620 kg	
R6105AZLD (1500 rpm) Fuel Consumption		
Power Rating	g/kWh	Litres/hr
At 100% of Prime Power Rating	231	20,51
At 75% of Prime Power Rating	229	15,38
At 50% of Prime Power Rating	232	13,33
At 25% of Prime Power Rating	235	10,81

Electrical System

Two types electrical system: 12 V and 24 V, all are single wire system with negative pole grounded.

- Battery – should be installed near the starting motor to avoid voltage drop
- Silicon rectified dynamo
- Voltage regulator – keep the voltage at the range of 13.5 – 14.5 V or 27 – 29 V.
- Starting Motor – full closed direct current series excitation motor

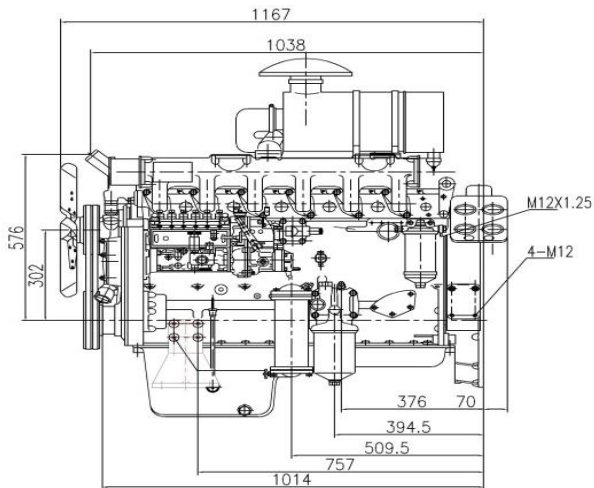

Performance Graph

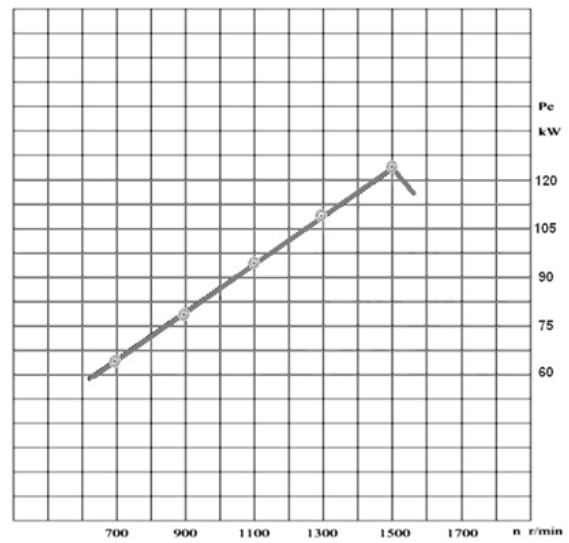

General Dimensions

