

# Starlite Series Engines



SA432G1

## SA432G1 Engine

fixed speeds  
1800 r/min

38 – 42 kWm | 50.9 – 56.3 bhp<sup>2</sup>

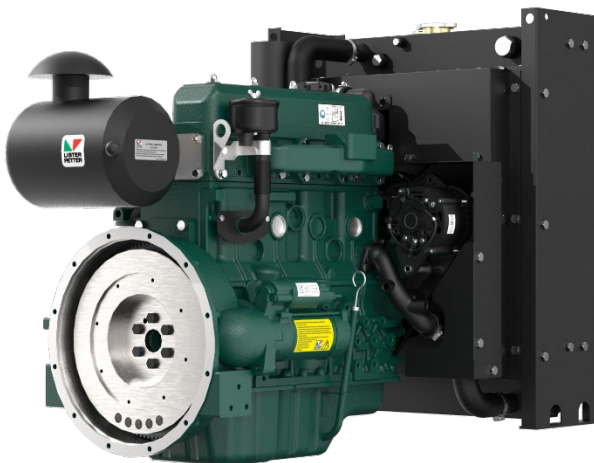

### OVER VIEW

The engine is specifically designed as a Power generating engine suitable for use in stage II emissions territories. It is durable, reliable and easy to maintain with oil & filter changes up to 500 hours, dependant on operational conditions. It is designed for continuous operation in ambient temperatures up to 52°C (125°F) and a cold start capability down to -25°C (-13°F).

G Build

Note:

For further information and approval please contact Applications Department

\* Optional items standard on most builds.

### BASIC ENGINE CHARACTERISTICS

- direct fuel injection
- 4 cylinders
- liquid cooled
- natural aspirated

### DESIGN FEATURES AND EQUIPMENT

- electric starting
- anti clockwise rotation, looking on the flywheel end
- SAE Flywheel connection
- SAE compliant flywheel housing
- radiator and fanguard
- cast-iron structural crankcase
- self-vent fuel injection system
- mechanical fuel injection equipment
- mechanical and electronic governing variants
- flywheel and gear ring
- cyclonic heavy duty air filtration
- oil pressure protection switch
- coolant temperature protection switch
- spin-on full flow lubricating oil filter
- fuel filter / agglomerator
- intake and exhaust manifolds
- operators' handbook

### OPTIONAL ITEMS

A range of options are available that allows you to select a specification that matches your requirements; please consult your Lister Petter Engine distributor.

**POWER OUTPUTS<sup>3</sup> | Stage II EMISSIONS RATINGS**

Model	Speed, r/min	Power	Gross <sup>2</sup>		Net		Standard Generator Output*		
			kW	bhp	kW	bhp	Power	kVA	kWe
SA432G1	1800	Continuous	38	50.9	37	49.6	PRP	40	32
		Fuel Stop	42	56.3	41	54.9	ESP	44	35

**TECHNICAL DATA**

Engine fixed speed 1800r/min	SA432G1	
Type of fuel injection	Direct	
Number of cylinders	4	
Aspiration	Natural	
Direction of rotation (flywheel end)	Anti clockwise	
Nominal cylinder bore	mm	98
	in	3.86
Stroke	mm	105
	in	4.13
Total cylinder capacity	litre	3.17
	in <sup>3</sup>	193.4
Compression ratio	18.5:1	
Firing order (number 1 cylinder is at the gear end)	1-3-4-2	
Alternator	14V×35A	
Starter motor	12V×3.8kW	
Fuel injection pump	Mechanical	
Speed governor	Electronic	
Speed regulation class	ISO 8528 G3	
Fly wheel housing	SAE 4	
Fly wheel	SAE J620 Size 75"	

**RATING DEFINITIONS TO ISO 3046****ISO Standard Conditions**

Barometric pressure 100kPa  
Relative humidity 30%  
Ambient air temperature at the inlet manifold 25°C

**Power Standards**

The engine performance corresponds to ISO 3046, BS 5514 and DIN 6271. The technical data applies to an engine without cooling fan and operating on a fuel with calorific value of 42.7 MJ/kg (18360 BTU/lb) and a density of 0.84 kg/liter (7.01 lb/US gal, 8.42 lb/Imp gal).

**Fixed Speed: Continuous Power (ICN)**

The power in kW which the engine is capable of delivering continuously at the stated crankshaft speed, under ISO 3046 standard conditions, measured at the flywheel without power-absorbing accessories, provided that the engine is overhauled and maintained in good operating condition and that fuel to BS EN 590 Class A1 or A2, and lubricating oils to the correct performance specification and viscosity classification as recommended by Lister Petter Engine Company are used.

**Fixed Speed (Fuel Stop): Overload Power (ICXN)**

The maximum power in kW which the engine is capable of delivering intermittently at the stated crankshaft speed for a period not exceeding one hour in any period of twelve hours of continuous running, immediately after working at the continuous power, under ISO 3046 standard conditions and with the provisions specified for continuous power in item (1) above, but with the fuel limited so that the fuel stop power cannot be exceeded.

**Derating**

For non-standard site conditions, reference should be made to relevant BS, ISO & DIN standards.

**Notes:**

- Power ratings are measured at the flywheel end.
- Power ratings and fuel consumption figures apply to a fully run-in, non derated engine without a radiator and fan fitted, and without power absorbing accessories or transmission equipment.

\* The power output of the generator data is calculated using a typical efficiency of the AC generator. The kVA and kWe values are converted as per standard power factor 0.8. Generator data is for reference only.

**EXHAUST AND INTAKE SYSTEM | 1800 RPM FIXED SPEED ENGINES**

Parameter	Engine Model
	SA432G1
<b>EXHAUST</b>	
Maximum allowable back-pressure (kPa)	≤ 10
Exhaust gas flow, (m <sup>3</sup> /min)	5.7
Emissions level	Stage II
Exhaust gas temperature, continuous (°C)	336
Exhaust gas temperature, overload (°C)	375
Exhaust pipe diameter - recommended	63.5mm
<b>INTAKE</b>	
Maximum allowable inlet restriction (kPa)	≤ 4
Combustion air flow (m <sup>3</sup> /min)	2.2

## ENGINE COOLANT SYSTEM | 1800 RPM, FIXED SPEED

Parameter	Engine Model
	SA432G1
Cooling method	Liquid cooled (belt driven water pump)
<b>RADIATOR</b>	
Material	Aluminium
Radiator face area (m <sup>2</sup> )	12.6
Pressure cap setting (kPa)	90
<b>FAN</b>	
Diameter (mm)	450
Number of blades	7
Material	Plastic
Type	Pusher
<b>COOLANT</b>	
Cooling package maximum operating temperature (°C)	≤110
Total system with radiator capacity (L)	11.4
Total system without radiator capacity (L)	4.8
Thermostat type	Wax Capsule
Thermostat opens at... (°C)	82 ± 2
Thermostat fully open at... (°C)	≤ 95
Minimum temperature to engine (°C)	-25
Maximum static pressure head at pump (meters at 1800rpm)	14
Cooling fan flow rate (l/sec)	55

### Recommended coolant:

50% ethylene glycol with a corrosion inhibitor (BS 6580 : 1992 or ASTM D3306-89 or AS2108) and 50% de-ionised water

## ENGINE LUBRICATION SYSTEM

Parameter	Engine Model
	SA432G1
Lubricating method	Pressure feed and splash
Sump capacity including filter(L)	8.0
Service Interval (hr)	500
Oil filter type	Spin-on full flow oil filter
Oil Specification	API CH-4
	ACEA E5
Oil consumption % SFC	≤ 0.1%
Oil consumption, 100% (l/hr)	0.016
Lubricating oil temperature (°C)	90-105
Maximum oil temperature (°C)	108
Maximum operation angle of engine (degrees)	10°

### APPROXIMATE FUEL CONSUMPTION

		Engine model	
Speed, r/min	Load	SA432G1	
		g/kWh	l/h
1800	110%	232	11.61
	100%	222	10.10
	75%	223	7.61
	50%	227	5.17
	25%	282	3.21

\*Diesel fuel density 0.835 g/ cm<sup>3</sup>

\* The power output of the engine is calculated according to NPT conditions.

\* For non-standard site conditions not listed, reference should be made to BS, ISO and DIN standards.

\* Inquiry should always be made to the technical department of the respective manufacturer if the attitude is above 3000m.

## ENGINE NOISE LEVELS

Parameter	Engine Model
	SA432G1
Sound pressure level at 1m	≤98 dB(A)

## APPROXIMATE DIMENSIONS AND WEIGHT

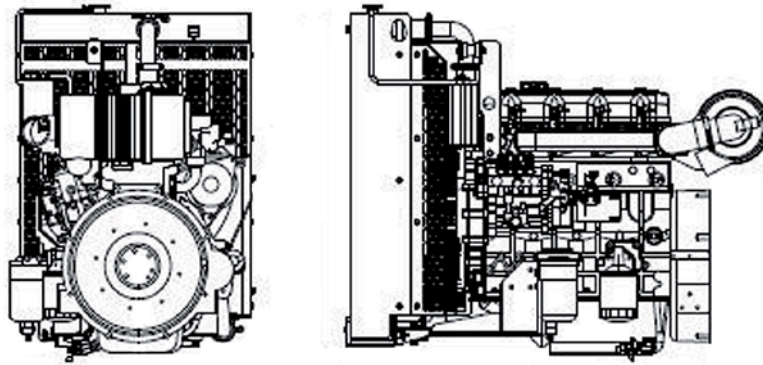

Engine model		SA432G1
Dry weight	kg	302
	lb	664
Length (A)	mm	970
	in	37.8
Width (B)	mm	670
	in	26.1
Height (C)	mm	845
	in	33.0

## TYPICAL PACKING CASE DIMENSIONS

Engine packing case dimensions	Radiator packing case dimensions	Container quantities ( Engine with Radiator)		
		20FT	40FT	40HQ
L*W*H(mm)	W*D*H(mm)			
965*715*983	760*390*980	24 sets	52 sets	52 sets



**Head Office**  
Lister Petter Engine Company Limited

Rutland House, Minerva Business Park,  
Lynch Wood, Peterborough, PE2 6PZ.

**Distributor Address**



enquiry@listerpetter.com  
www.listerpetter.com