

Non-Emission

Model	Sale Model	rpm	Gross Engine Output [kW]		Net Engine Output [kW]	
			Stand-by	Prime	Stand-by	Prime
DC03-OOG02	SP344CA	1500	50.8	46.1	49.0	44.3
		1800	57.6	52.3	54.1	48.8
DC03-OOG01	SP344CB	1500	61.4	55.6	59.6	53.8
		1800	73.5	66.6	70.0	63.1
DC03-OOG00	SP344CC	1500	81.4	73.3	79.6	71.5
		1800	92.2	83.0	88.7	79.5



Ratings Definitions

The power ratings of Emergency Standby and Prime are in accordance with ISO 8528.

Electric power(kWe) should be estimated by considering generator efficiency, cooling fan power loss and power derating due to altitude and ambient temperature.

STANDBY POWER RATING is applicable for supplying emergency power for the duration of the utility power outage.

No overload capability is available for this rating. A standby rated engine should be sized for a maximum of an 70% average load factor and 200 hours of operation per year. This includes less than 25 hours per year at the Standby Power rating.

PRIME POWER RATING is available for an unlimited of hours per year in variable load application. Variable load should not exceed a 70% average of the Prime Power rating during any operating period of 24 hours. The Total operating time at 100% Prime Power shall not exceed 500 hours per year. A 10% overload capability is available for a period of 1 hour within a 12 hour period of operation.

Total operating time at the 10% overload power shall not exceed 25 hours per year.

◎ GENERAL ENGINE DATA

○ Engine Model	DC03-OOG00, DC03-OOG01, DC03-OOG02
○ Engine Type	4-stroke, in-line 4 cylinder, water cooled, common rail direct injection
○ Bore x stroke	98 x 113 mm
○ Displacement	3.4 liters
○ Compression ratio	16.8 : 1
○ Rotation	Counter clockwise viewed from flywheel
○ Firing order	1 - 3 - 4 - 2
○ Dry weight	373 kg (engine only)
○ Dimension (LxWxH)	800 x 676 x 813 mm
○ Idle speed	800 ±15 rpm
○ Maximum permissible high altitude (No torque derating)	2500 m
○ Moment of inertia	0.804 kgm ²
○ Flywheel housing	SAE J617 #3
○ Flywheel	SAE J620 11.5"
○ Number of teeth on flywheel ring gear	125

◎ AIR INTAKE SYSTEM

○ The maximum temperature rise	15 °C
○ Maximum inlet temperature	52 °C
○ Minimum inlet pressure	100 kPa
○ Max. permissible air intake restriction at engine (dirty filter)	6.5 kPa
○ Max. permissible air intake restriction at engine (clean filter)	3 kPa
○ Air filter type	Dry Element Type
○ Minimum dirt capacity	1200 g

◎ EXHAUST SYSTEM

○ Maximum permissible back pressure for total system	6 kPa
○ Exhaust gas flow(prime)	5.5 (1500rpm), 6.8 (1800rpm) m ³ /min
○ Exhaust gas flow(standby)	5.5 (1500rpm), 6.8 (1800rpm) m ³ /min
○ Exhaust gas temperature(prime)	453 (1500rpm), 453 (1800rpm) °C
○ Exhaust gas temperature(standby)	497 (1500rpm), 509 (1800rpm) °C

COOLING SYSTEM

○ Cooling method	Coolant forced circulation by centrifugal pump on engine
□ Total system coolant capacity	14.2 L with Power Pack (Radiator ASSY); Engine only: 4 L;
○ Coolant flow rate	min. 98 L/min @1500rpm / min. 118 L/min @ 1800rpm
○ Thermostat operation range	80 ~ 90 °C
○ Maximum permissible external system resistance	25 kPa
○ Maximum temperature to engine	105 °C
○ Minimum temperature to engine	70 °C
○ Coolant temperature alarm	105 °C
○ Limits of the environment temperature	52 °C
○ Thermostat type and range	Wax-pellet type, opening temp. 80 °C / full open temp. 90 °C

RADIATOR SYSTEM

○ Radiator	Fin & Tube (Option)
○ Radiator cooling area	Water Tank: 34.9 m ² / Inter-Cooler: 7.5 m ²
○ Length x height x width	740 x 977 x 338 mm
○ Pressure cap setting	0.9 ± 0.15 kPa
○ Maximum top tank temperature	105 °C

FAN SYSTEM

○ Diameter	480 mm (Option)
○ Driver ratio	1 : 1.3 (Crank : Fan)
○ Number of blade	7
○ Material	Plastic
○ Fan flow	118.8 (1500rpm), 141 (1800rpm) m ³ /min

LUBRICATION SYSTEM

○ Lubrication method	Fully forced pressure feed type
○ Lubrication pump	Gear type driven by crankshaft gear
□ Lubrication oil capacity	6 ~ 12.6 L
○ Lubrication oil pressure	min 250 kPa (1500rpm) / min 300 kPa (1800rpm)
○ Lubrication oil temperature	105 (max 125)°C
○ Lubrication oil consumption as % of fuel consumption	0.1 % maximum
○ Pressure of oil relief valve opening	550 ± 50 kPa
○ Oil filter	Full flow, spin-on type
○ Angularity limit	all direction 35 deg.
○ Lubrication oil	Refer to operation manual

FUEL SYSTEM

○ Injection pump	BOSCH high pressure common rail pump
○ System inlet pressure	0.35 ~ 1 bar abs.
○ System pressure	1800 bar
○ Feed pump	Mechanical type integrated with injection pump
○ Injection nozzle	Multi hole type
○ Fuel filter	Full flow, spin-on type (Pre-filter with water in fuel sensor)
○ Fuel type	Diesel fuel

ELECTRICAL SYSTEM

○ System voltage	12 V
□ Alternator	12 V / 110 A
○ Starter motor	12 V / 2.5 kW
○ Starting aid	Glow plug

VALVE SYSTEM

○ Type	Over head valve
○ Number of valve	Intake 2, exhaust 2 per cylinder
○ Valve lashes at cold	Intake 0.4 mm / exhaust 0.45 mm

◎ PERFORMANCE DATA		Prime power(DC03-OOG00/01/02)		Standby power(DC03-OOG00/01/02)	
○ Engine speed	rpm	1500	1800	1500	1800
○ Idle speed	rpm	800	800	800	800
○ Over speed limit	rpm	1650	1980	1650	1980
○ Gross engine power output	kW	73.3 / 55.6 / 46.1	83.0 / 66.6 / 52.3	81.4 / 61.4 / 50.8	92.2 / 73.5 / 57.6
	PS	99.7 / 75.6 / 62.7	112.8 / 90.5 / 71.1	110.7 / 83.5 / 69.1	125.4 / 99.9 / 78.4
○ Break mean eff. Pressure	Mpa	1.72 / 1.30 / 1.08	1.62 / 1.30 / 1.02	1.91 / 1.44 / 1.19	1.80 / 1.44 / 1.13
○ Mean piston speed	m/s	5.7	6.8	5.7	6.8
○ Friction power	kW	8.0	11.0	8.0	11.0
	PS	10.9	15.0	10.9	15.0
○ Specific fuel consumption					
25% Load	L/hr	5.7 / 4.4 / 4.0	6.7 / 5.7 / 4.9	6.3 / 4.8 / 4.3	7.6 / 6.2 / 5.4
50% Load	L/hr	9.5 / 7.4 / 6.4	11.3 / 9.3 / 7.8	10.6 / 8.1 / 7.0	12.8 / 10.1 / 8.6
75% Load	L/hr	13.7 / 10.5 / 9.0	15.7 / 13.1 / 10.6	15.2 / 11.5 / 9.8	17.7 / 14.2 / 11.8
100% Load	L/hr	18.2 / 13.7 / 11.6	20.7 / 16.7 / 13.4	20.2 / 15.1 / 12.6	23.3 / 18.1 / 14.8
○ Max. lube oil consumption	g/hr	12.0	12.0	12.0	12.0
○ Fan power	kW	1.8	3.5	1.8	3.5

◎ ENGINE DATA with EXH. MANIFOL		Prime power(DC03-OOG00/01/02)		Standby power(DC03-OOG00/01/02)	
○ Intake air flow	m3/min	5.1 / 4.6 / 4.2	6.4 / 6.2 / 5.9	5.2 / 4.8 / 4.4	6.4 / 6.2 / 6.1
○ Exhaust gas temp. after TC	℃	453 / 372 / 347	453 / 359 / 303	497 / 383 / 357	509 / 391 / 322
○ Heat rejection to exhaust	kW	50.0 / 37.2 / 32.2	52.2 / 46.7 / 37.1	56.0 / 41.4 / 35.0	69.7 / 52.1 / 40.1
○ Heat rejection to coolant	kW	39.5 / 31.9 / 27.0	4.6 / 38.0 / 32.3	44.0 / 33.9 / 28.6	47.8 / 40.3 / 34.2
○ Heat rejection to intercooler	kW	11.7 / 8.8 / 7.0	4.3 / 13.1 / 11.7	12.1 / 10.0 / 8.0	14.4 / 13.3 / 12.3
○ Radiated heat to ambient	kW	1.2 / 1.6 / 0.9	2.3 / 1.1 / 1.0	2.1 / 1.5 / 2.5	2.2 / 0.9 / 1.5
○ Cooling water circulation	liters/min	98	118	98	118
○ Cooling fan air flow	m3/min	118.8	141	118.8	141

◎ ENGINE DIMENSION

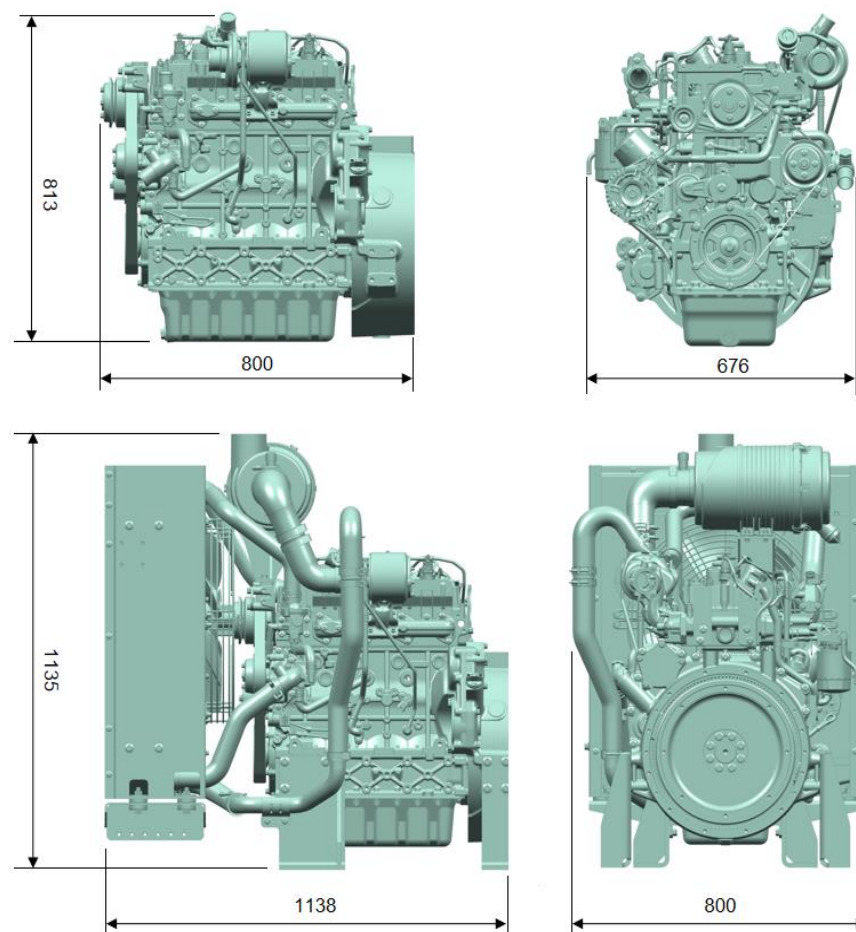

◆ CONVERSION TABLE

in. = mm x 0.0394

PS = kW x 1.3596

psi = kg/cm² x 14.2233

in³ = lit. x 61.02

hp = PS x 0.98635

lb = kg x 2.20462

kW = kcal/sec x 0.239

lb/ft = N.m x 0.737

U.S. gal = lit. x 0.264

kW = 0.2388 kcal/s

lb/PS.h = g/kW.h x 0.00162

cfm = m³/min x 35.336

MPa = kPa x 1000 = bar x 10

HD Hyundai Infracore Co., Ltd.

14F, 477, Bundangsuseo-ro, Bundang-gu, Seongnam-si,

Gyeonggi-do, Republic of Korea 13553

Email : enginesales@hd.com

Website : www.hd-hyundaiengine.com

※Specifications are subject to change without prior notice.

